



World Robot Olympiad 2019

Advanced Robotics Category

Game Description, Rules and Scoring

SMART Greenhouse

Version: January 15th



WRO International Premium Partners



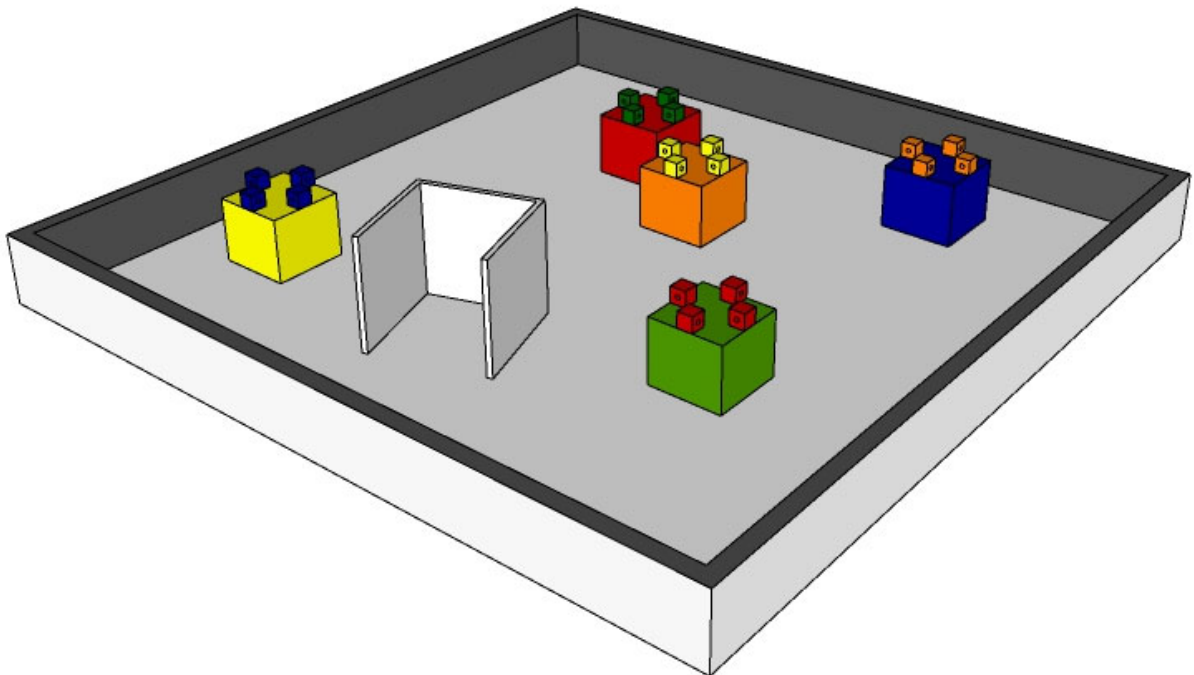

Table of Contents

1. Introduction.....	3
2. Game Description.....	4
3. Game Alternatives.....	6
4. Game Rules.....	9
5. Scoring.....	10
6. Field Specification.....	13
7. Appendix A.....	23
8. Appendix B.....	25
9. Appendix C.....	29
10. Appendix D.....	31

1. Introduction

The challenge is to make a robot that can score as many points as possible in a robot version of the autonomous operation of gardening in a green house. This year the team must design and program robot that can do localization and mapping for the playground that simulate different environment of a green house in order to garden the green house.



2. Game Description

A greenhouse is a closed structure that provide different regulated climate for plants. The greenhouse is represented by open square table. The greenhouse contains plants in the growth stage which are represented by small cubes laying on the top of boxes. The boxes represent different climate which differs in the illumination and warming conditions. There are 5 boxes of 5 different colors and on top of each box there are 4 small cubes which not from the same color of the box and they are located in the four known direction (right, left, forward and backward). The boxes do not have a fixed position inside the table. The robot must start from a parking zone represented by white box that have open side. Figure 1 shows the game field.

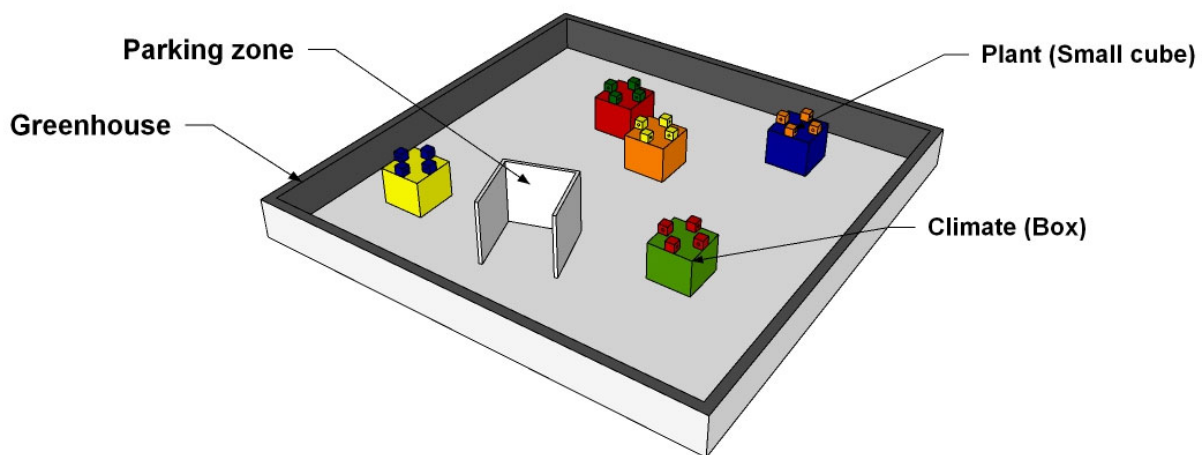

Figure 1. Detailed game field

Notice that the positions of the boxes are randomly defined during the drawing before every attempt of the round.

The robot's task is to move some plants from climate to another one which is represented in the playground as moving the small cubes from top of the boxes to another one.

The robot should identify only three needed cubes on the boxes by the following rules and move them to another box:

1. The first cube is located always on the blue box on that side of the box which is the opposite side to the side which is facing the closest wall.

2. The color of the cube on the blue box identifies the second box. So, the first cube should be moved to this box.
3. The second cube is located on the second box on that side of the box which is the opposite side to the side which is facing the closest wall.
4. The color of the cube on the second box identifies the third box. So, the second cube should be moved to this box.
5. The third cube is located on the third box on that side of the box which is the opposite side to the side which is facing the closest wall.
6. The third cube must be moved to the parking box (could be on top of or within the robot).

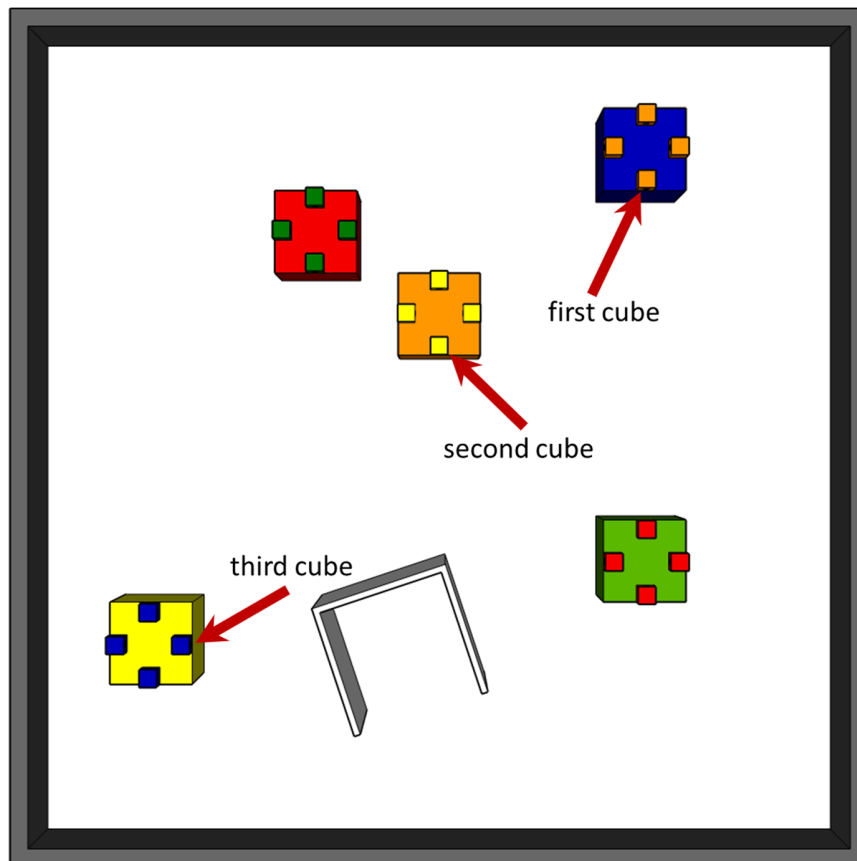

Figure 2. Cubes that need to be handled.

3. Game Alternatives

There are two types of matches: qualifying matches and final matches.

For the International Final it will be held: 3 qualifying matches and 2 final matches.

During **qualifying matches**, judges will provide a QR-code which will be located on inner side of the parking box in order to make the robot able to scan it. This QR-code will have specific text form which will allow to identify the position and the direction of the parking box and the coordinates of needed boxes (without their colors) in the following form:

“($X_{p1}, Y_{p1}, X_{p2}, Y_{p2}$) (X_1, Y_1, X_2, Y_2) (X_3, Y_3, X_4, Y_4) (X_5, Y_5, X_6, Y_6)”.

X_{p1}, Y_{p1} : the coordinates of the upper-right point of the inner edge of the parking zone.

X_{p2}, Y_{p2} : the coordinates of the lower-right point that lies on the inner edge of the parking zone. Refer to **figure 17** for details.

X_1, Y_1 : the coordinates of the upper-left point of the first needed box.

X_2, Y_2 : the coordinates of the lower-right point of the first needed box.

X_3, Y_3 : the coordinates of the upper-left point of the second needed box.

X_4, Y_4 : the coordinates of the lower-right point of the second needed box.

X_5, Y_5 : the coordinates of the upper-left point of the third needed box.

X_6, Y_6 : the coordinates of the lower-right point of the third needed box.

The coordinates are represented by English letters from A to U which represent crosses of a grid on the playground.

There are no space characters in the text coding position of needed boxes.

The QR-code is generated as per description of algorithm available on <https://www.thonky.com/qr-code-tutorial/>.

See **figure 4** and **figure 8** for more illustration.

Examples of location of game elements and corresponding QR-codes can be found in the Appendix C.



**Figure 3. QR Code represents the text “(K,Q,J,N)(I,I,K,G)(N,C,P,E)(E,O,C,Q)”
(generated by <https://www.thonky.com/qrcode/>)**

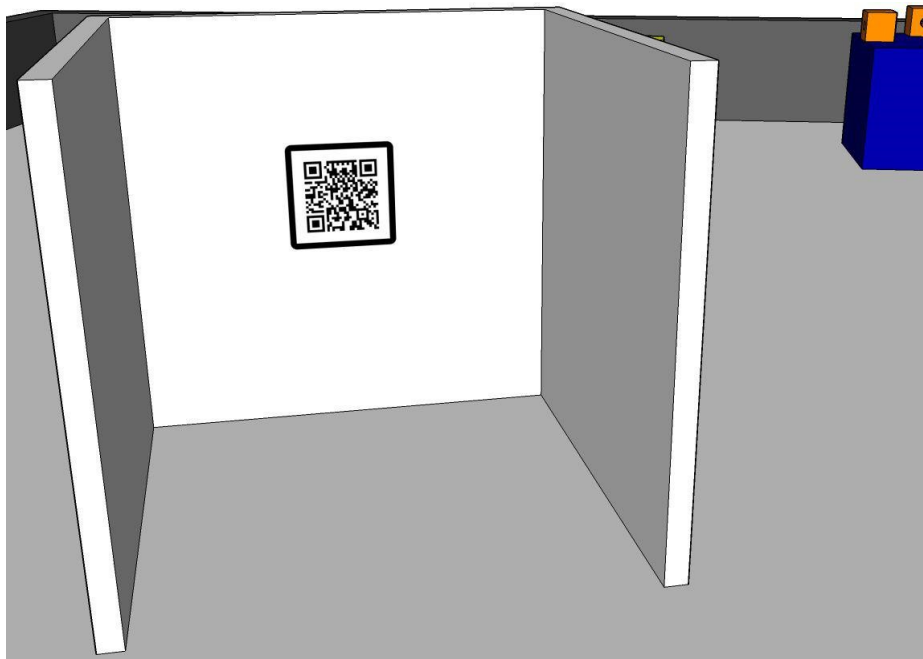

Figure 4. QR Code within the parking box.

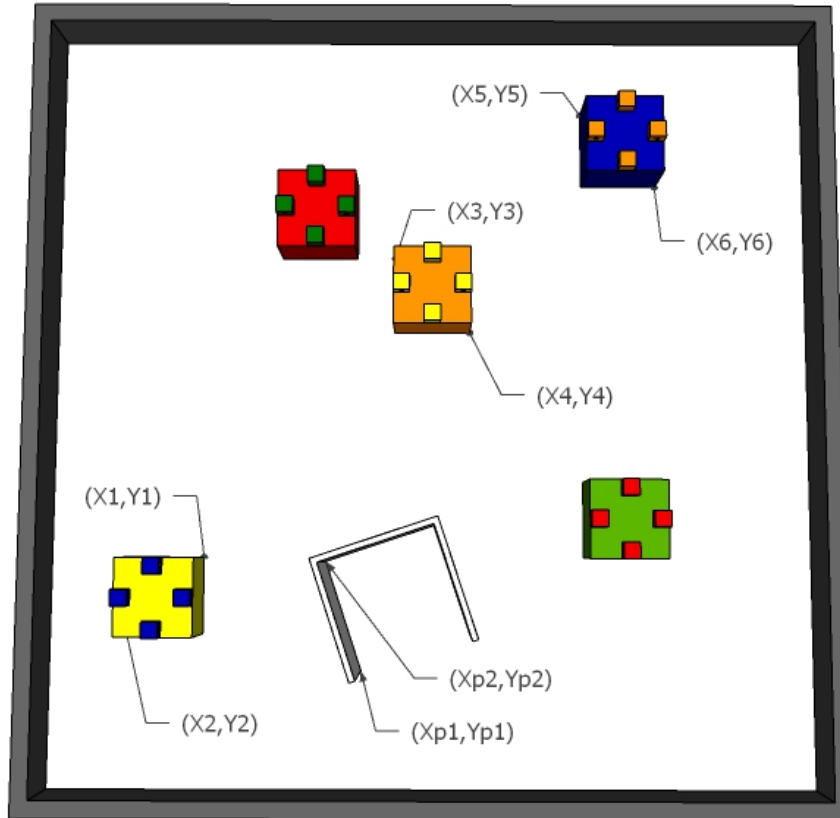

Figure 5. Illustration for meaning of the coordinates coded in the QR-code.

Notice that in the qualifying round, it is not necessary to provide the QR-code depending on the decision of the judges and the organizers to make the competition more difficult and more competitive, however, teams must know that before the competition through the organizer. For the International Final, the QR-codes will be used in the qualifying rounds.

During **final matches**, No QR Code will be provided. So, the robot must discover location of boxes itself.

4. Game Rules

Match Timing:

- Every qualifying match is three minutes in length.
- Every final match is five minutes in length.

Starting Configuration:

- The positions of the boxes and the parking zone are unknown before the starting of the round. The positions are selected randomly by the judges before the start of the round but it is assured that the boxes will be parallel to the wall of the table. But the parking zone not necessary to be parallel to the table's wall; See **Appendix A** and **Appendix B** to see the possible orientations of the boxes and the parking box respectively.

The special web-application accessible on <https://arc.wro-association.org> will be provided to simplify the procedure of drawing.

- The positions of the boxes and the parking zone are the same for all teams during the same round.

Match Start:

- The robot must start from the parking zone which means the robot should be inside the parking zone and no part of the robot is allowed to be outside of the parking box in the starting time.
- The robot's dimensions must not exceed 345 x 345 x 345 mm in the starting (cables are allowed to be outside of this size) but it can exceed the dimensions in width and length but not the height during the round.
- The match timer starts when the judge gives the signal to start.

Additional Pieces:

- The robot must not leave the additional pieces on the game field during the match.

During the Match:

- The robot is not allowed to move the boxes neither nor the parking zone. Moreover, if the robot violates this rule during its round, the attempt will not be stopped but

the robot will get zero score for this round. The box is considered to be moved from the initial position if one of box's corners is farther than 10 mm from the cross where it was located before the robot started.

- The robot is allowed to move cubes from one box to another in any order.
- The robot is allowed only to move the needed cubes which are described in the game description.
- The robot should not move other cubes.
- The robot must return to the parking zone to get additional points.

Match End:

- The match ends and time is stopped if any of the following conditions occurs:
 - The match timer expires
 - Any team member touches the robot
 - Any team member touches the field mat, wall or a game elements
 - The robot places a cube outside of the game field or drives outside of the game field.
 - The robot or team member damages the field or a game element (box, cube)
 - The projection of the robot is completely the parking zone (cables can be outside)

5. Scoring

The official score will be calculated at the end of each round.

The maximum score depends on the type of round:

- Qualifying round is 65 points
- Final round is 130 points

In the score table, there are three types of the cube location:

- If the cube’s projection is completely within the gray square on top of the box – the cube is considered as completely in the zone.
- If any part of the cube’s projection touches the area outside of the gray square on top of the box but there is a part of the cube’s projection that is still within the gray zone – the cube is considered as partially in the zone.
- If the cube’s projection is completely outside of the gray square on top of the box – the cube is considered as completely out of the zone.

Similar is applicable to the location of the robot within the parking box:

- If the robot’s projection (without cables) is completely within the square formed by the projection of the parking zone – the robot is considered as completely in the parking box.
- If any part of the robot’s projection (without cables) touches the area outside of the square formed by the projection of the parking zone but there is a part of the robot’s projection that is still within the square – the robot is considered as partially in the parking box.

There are illustrations about “in the zone”, “partially in the zone” and “out of the zone” in the **Appendix D**.

	Requirements	Qualifying rounds		Final rounds	
		Point value	Total Available	Point value	Total Available
1.	Picking the cube. Only boxes from 2.1, 2.3 and 2.5 of Game Description are being taken into account.				
1.1.	The cube initially located on required side of required box is completely out of the zone. Other three cubes on this box are completely within the zones they were placed initially.	5	15	10	30
1.2.	The cube initially located on wrong side of required box is completely out of the zone. Other three cubes on this box are completely within the zones they were placed initially.	1	3	2	6
1.3.	Any cube initially located on required box is partially in the zone. Other three cubes on this box are completely within the zones they were placed initially.	0	0	0	0

1.4.	At least two cubes initially located on required box are partially in the zone or completely out of the zone.	0	0	0	0
2.	Placing the cube. The color of the cube matches the color of the box. Only boxes from 2.1, 2.3 and 2.5 of Game Description are being taken into account.				
2.1	The cube is on required side of the box and completely within or partially in the zone. There is no another cube that is completely within or partially in the same zone. Yet three cubes on this box are completely within the zones they were placed initially. Only four cubes on the box.	10	20	20	40
2.2.	The cube is on required side of the box and completely within or partially in the zone. There is another cube that is completely within or partially in the same zone. Yet three cubes on this box are completely within the zones they were placed initially.	2	4	4	8
2.3.	The cube is on wrong side of the box and completely within or partially in the zone. There is no another cube that is completely within or partially in the same zone. Yet three cubes on this box are completely within the zones they were placed initially. Only four cubes on the box.	2	4	4	8
2.4.	The cube is on wrong side of the box and completely within or partially in the zone. There is another cube that is completely within or partially in the same zone. Yet three cubes on this box are completely within the zones they were placed initially.	2	4	4	8
2.5.	The cube is on the box (the side does not matter) and completely within or partially in one zone. There is, at least, one more cube on the same box that is completely outside or partially in another zone.	0	0	0	0
3.	Taking the cube into the parking zone.				
3.1.	The projection of the cube picked from the third box (2.5 of Game Description, but the side does not matter) is completely within the	10	10	20	20

	square formed by the projection of the parking zone.				
4.	Bonus. The first, second and third boxes are from 2.1, 2.3 and 2.5 of Game Description				
4.1.	There are only three cubes of the same color on the first box. There is one cube of the same color as the second box on the second box and it is completely within or partially in the zone. There is one cube of the same color as the third box on the third box and it is completely within or partially in the zone. Each of rest two box contains by four cubes completely within the zones they were placed initially. There is no two cubes of the same color touching the same zone on any boxes.	5	5	10	10
5.	Parking				
5.1	The robot is partially in the parking box. There is, at least, one cube that is completely out of the zone located on one of required boxes (the side does not matter). Other three cubes on this box are completely within the zones they were placed initially.	5	5	10	10
5.2.	The robot is completely within the parking box. There is, at least, one cube that is completely out of the zone located on one of required boxes (the side does not matter). Other three cubes on this box are completely within the zones they were placed initially.	15	15	30	30

6. Field Specification

- Challenge's table:
 - Square table (2400 x 2400 x 200 mm) (+/-5mm). 200 mm is the inner height.
 - The ground's color is white, the inner wall's color is black and the outer wall's color is black.
 - The wall's thickness is 50mm.

- The dimension of the grid's cell is (115 x 115 mm) (+/- 2mm).
- There are crosses on the table which help the judges to position the boxes. However, the robot will not be able to use grid crosses for line following as the thickness of the strokes is 1 mm or less. The color of strokes is light grey, PANTONE Cool Gray 5 C, RGB (177 179 179)
- There are line stripes positioned as it is illustrated in **figure 6**. The thickness and the color of the lines are the same as the crosses.
- The crosses will be indicated by the letters which will work as coordinates for the crosses to help in the process of positioning the boxes during the preparation of the round and also these are the coordinates which will be in the QR-code. See **figure 8** for more illustration.
- The robot should not use the letters to map the playground as they are proposed not to exist.

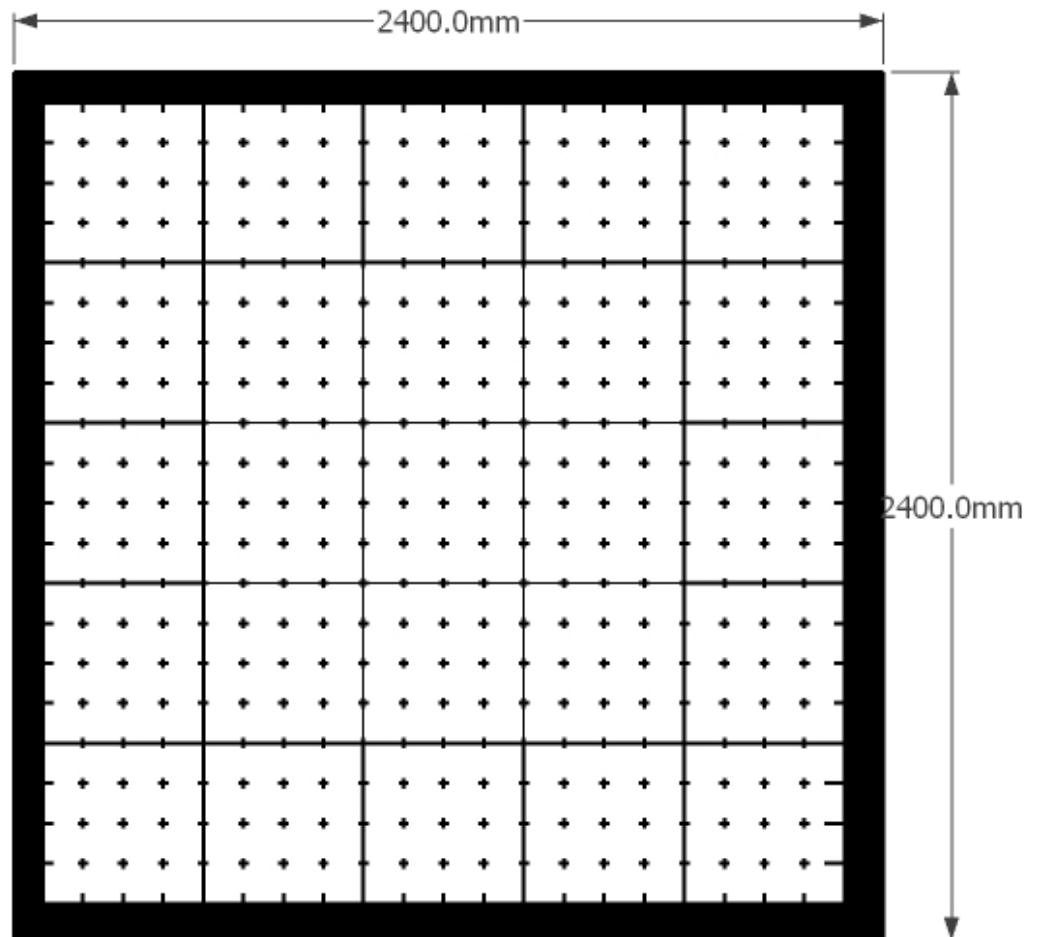

Figure 6. The dimension of the challenge's table.

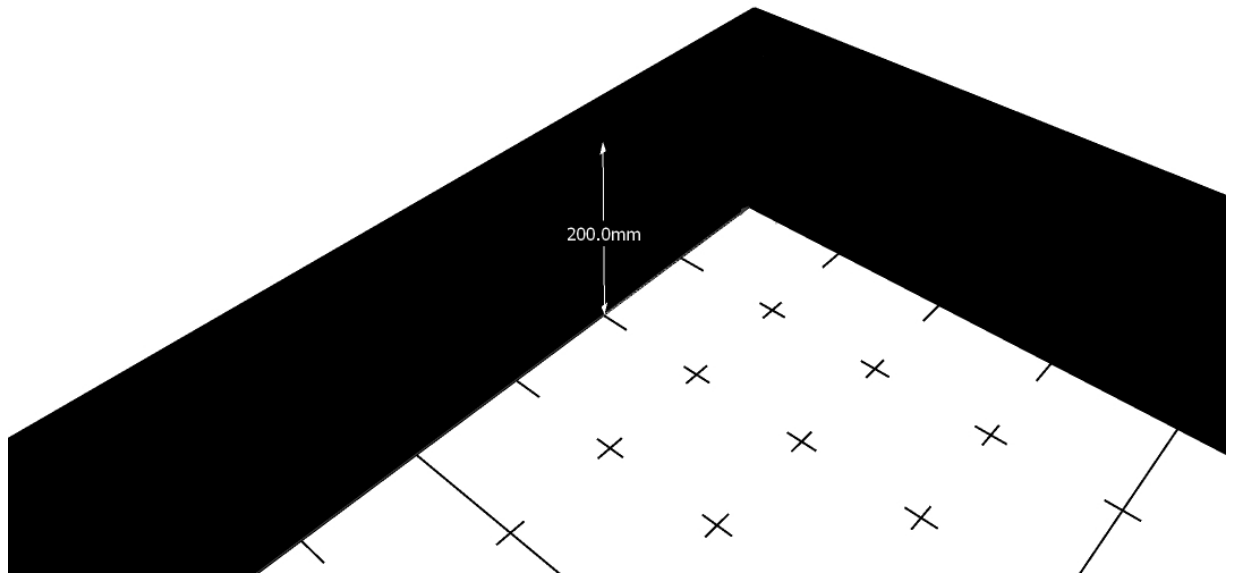

Figure 7. The inner wall's dimension.

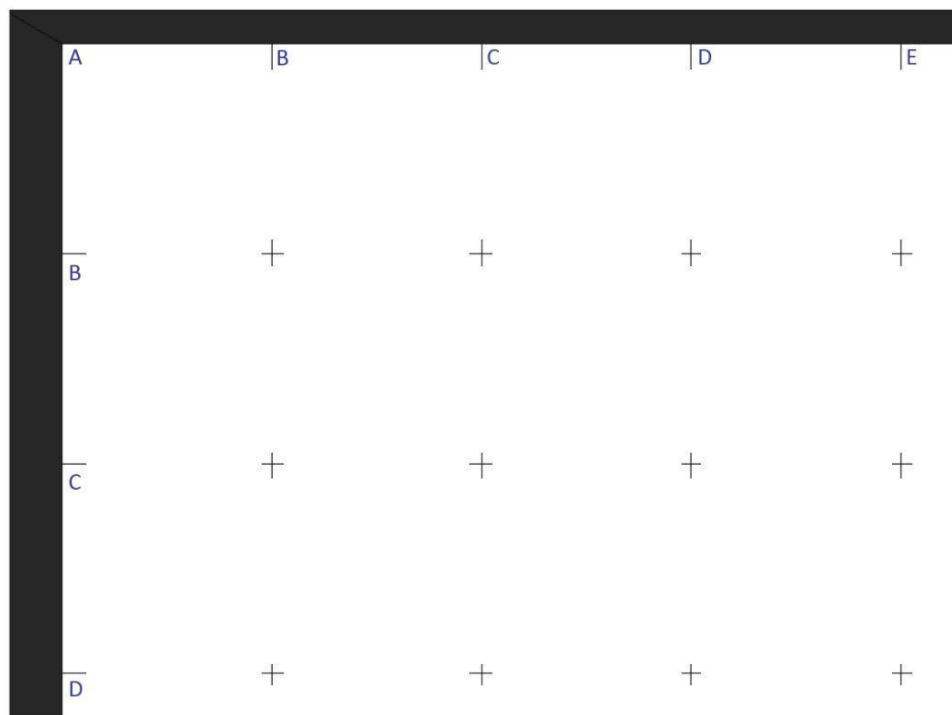

Figure 8. Illustration of the table with the letters.

- Parking zone:
 - Open side hollow cuboid (362 x 379 x 345 mm) (+/- 5mm).
 - The dimension of the inner cuboid which the robot can be there is (345 x 345 x 345 mm).
 - The parking zone's color is white.
 - The QR-code (in qualifying rounds only) will be generated by based on the description available on <https://www.thonky.com/qr-code-tutorial/>.
 - The QR-code's dimensions are (85 x 85 mm) and it will be centered on the face of the cuboid as Figure 10.
 - The QR-code is positioned as described in figure 11.
 - There will be square which is drawn in the place of the QR-code to guide the judges the place of the QR-code.

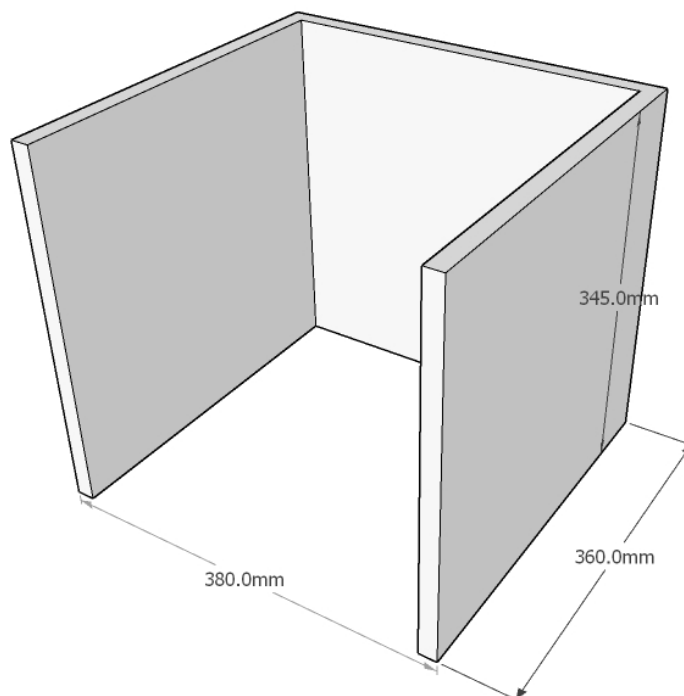

Figure 9. Dimensions of the parking zone.

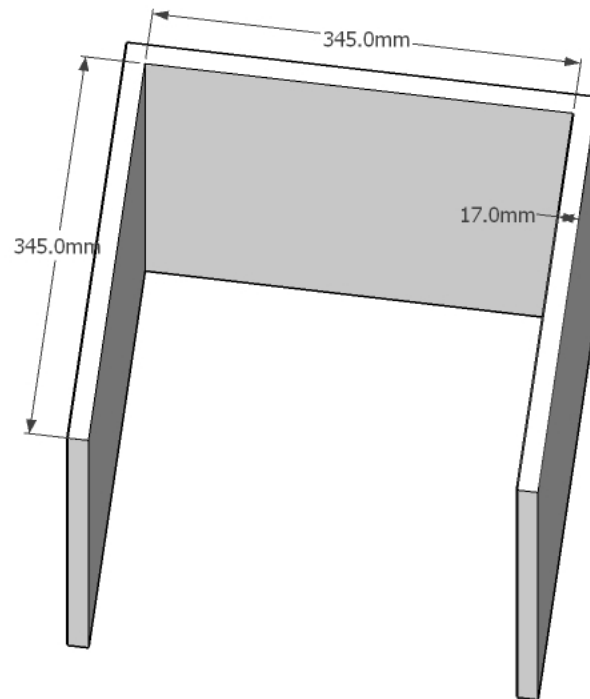

Figure 10. Inner dimensions of the parking zone.

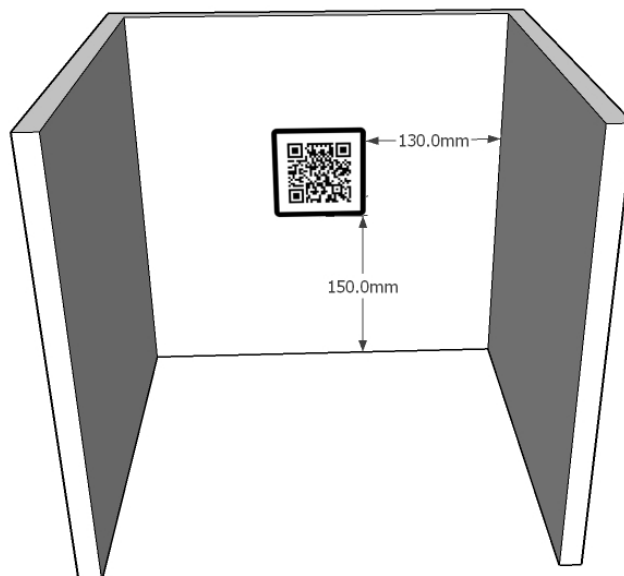

Figure 11. QR-code on the face of the cuboid.

- Boxes:
 - Solid cubes (230 x 230 x 200 mm) (+/- 2mm).
 - On the table, there will be 5 boxes. The colors of the boxes are:
 - Blue, PANTONE Blue 072 C, RGB (16, 6, 159).
 - Red, PANTONE 1795 C, RGB (238, 39, 55).
 - Green, PANTONE 802 C, RGB (68, 214, 44).
 - Orange, PANTONE Bright Orange C, RGB (254, 94, 0).
 - Yellow, PANTONE 803 C, RGB (254, 233, 0).
 - The box's material is wood.
 - There are guiding squares which have the same dimensions of the cubes to indicate the exact positions of the small cubes on top of the box.
 - There are square with grey color (RGB [86, 86,86]) which the robot is allowed to place the cubes in it during the round.
 - The dimensions of the grey squares are (60 x 60 mm).
 - This grey square is made to ease the process of placing the cubes on the box.
 - It is assured that the positions of the boxes which are defined by a drawing procedure will be reachable from the opposite side to the closest side to the wall. See **Appendix A** for more details.
 - Minimal difference between distances for every the box's side and the wall this side is facing to is 2300 mm.

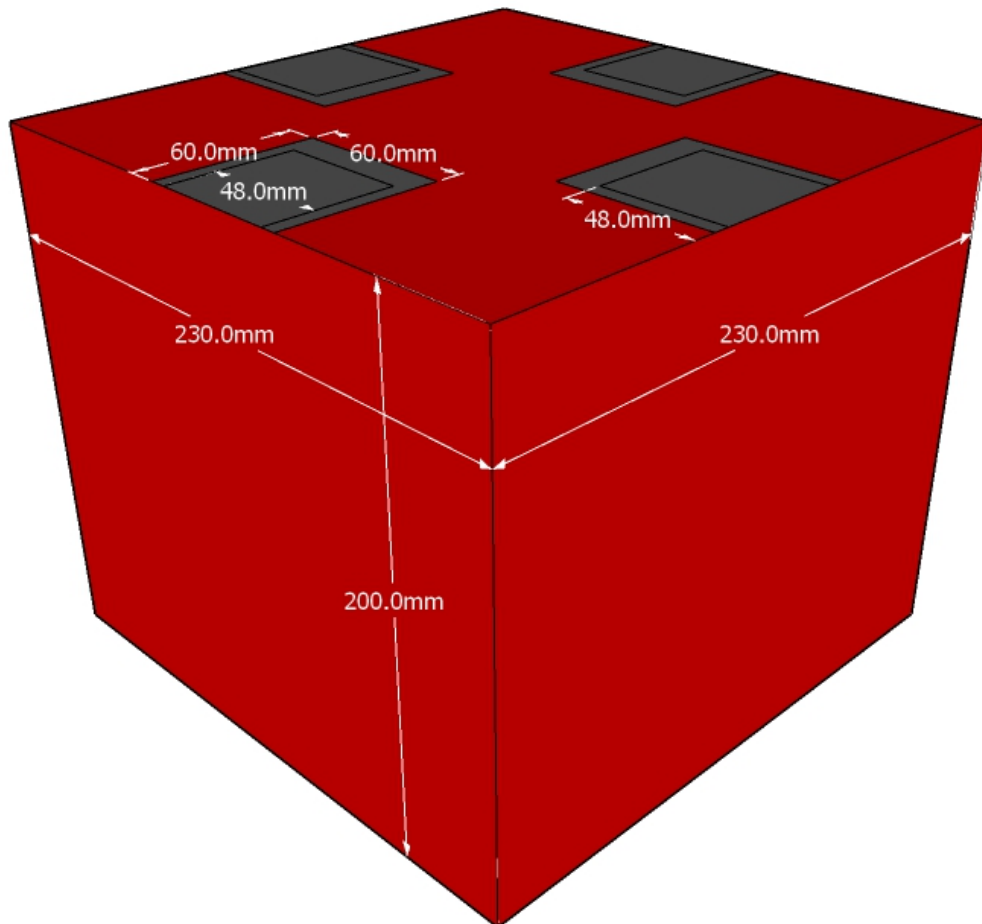

Figure 12. Box's dimensions.

- Cubes:
 - Solid cubes (48 x 48 x 48 mm) (+/- 2mm) with hollow cylinder in the middle through the cube (Ø 15mm +/-1mm).
 - There will 4 boxes on the top of each box.
 - The colors of the cubes are:
 - Blue, PANTONE Blue 072 C, RGB (16, 6, 159).
 - Red, PANTONE 1795 C, RGB (238, 39, 55).
 - Green, PANTONE 802 C, RGB (68, 214, 44).
 - Orange, PANTONE Bright Orange C, RGB (254, 94, 0).
 - Yellow, PANTONE 803 C, RGB (254, 233, 0).
 - The cube's material is wood.
 - The positions of the cubes are illustrated in the **figure 13**.

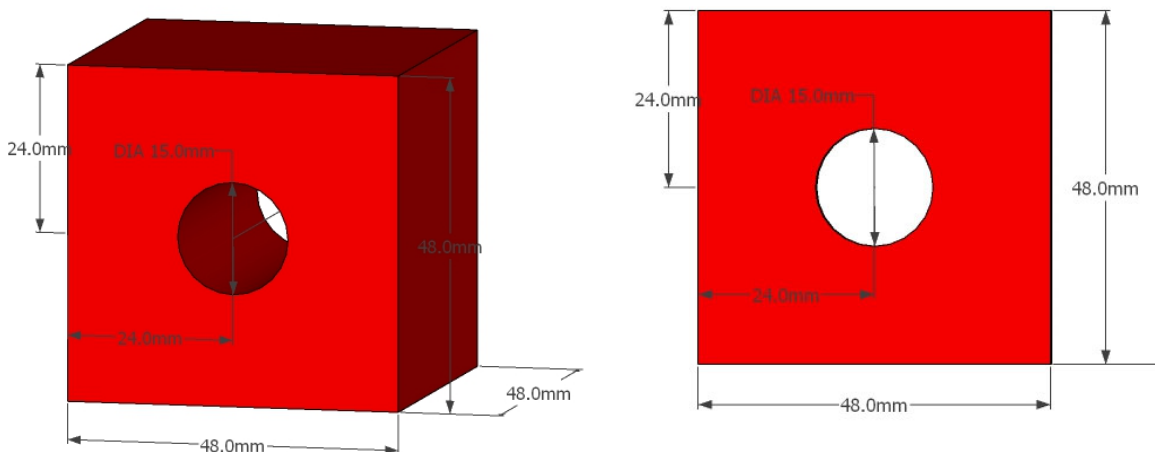

Figure 13. Cube's dimensions.

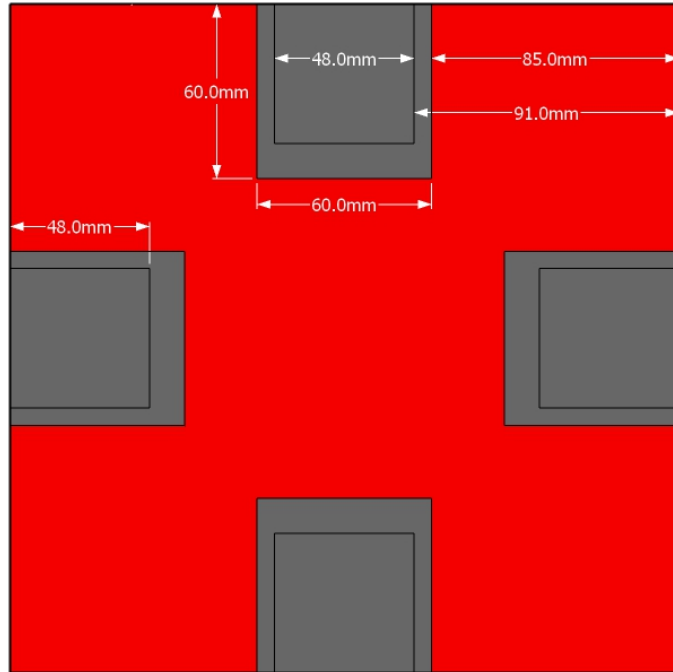

Figure 14. Illustration of cubes' positions on top of a box.

7. Appendix A

The possible positions of the boxes

- The boxes will be positioned using the crosses on the playground.
- There will be a free space in front of the side of the needed cube to ensure that it will be possible to be reached by the robot.
- The free space is a square (460 x 460 mm).
- The free space should be totally free as it doesn't contain any field items.
- The free space is not colored.

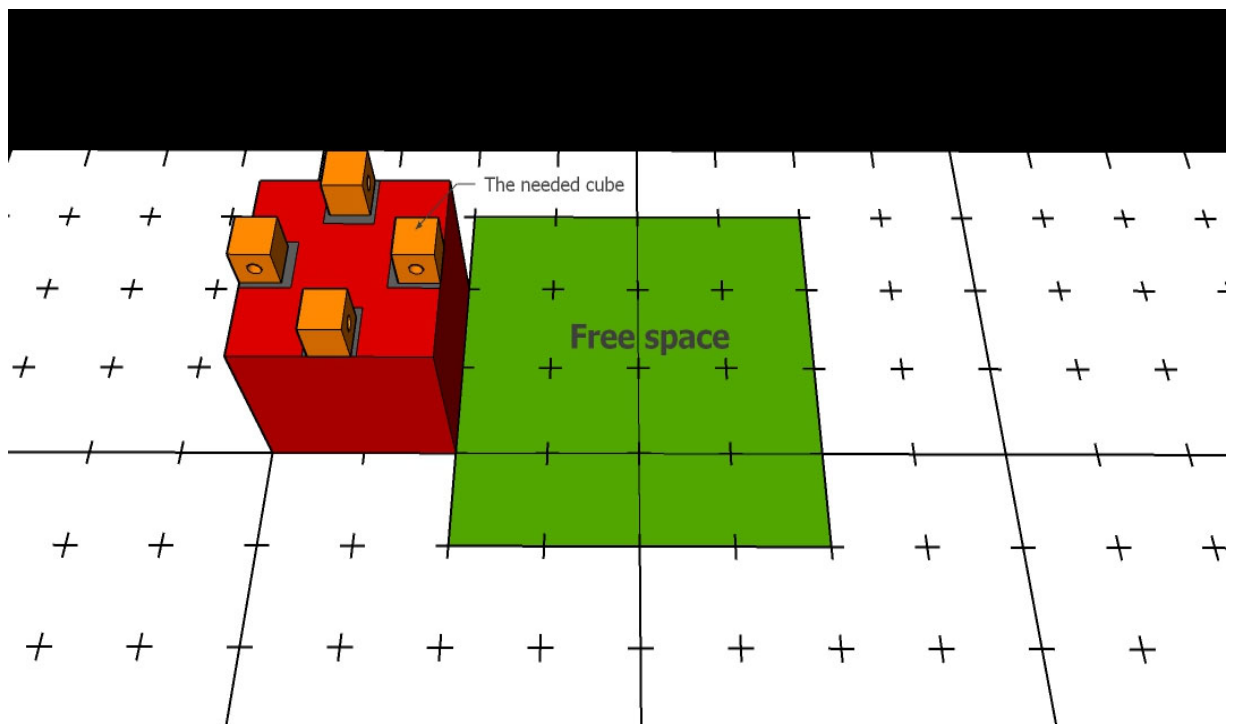

Figure 15. Right position for a Box.

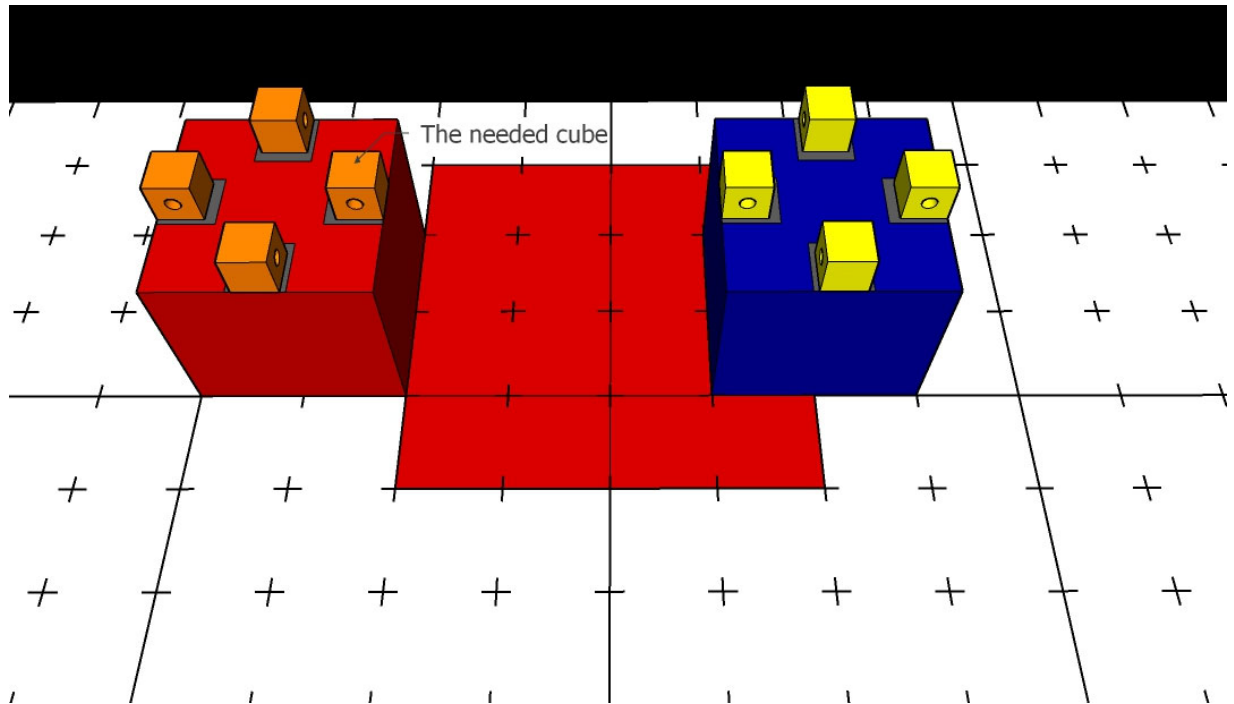

Figure 16. Wrong position for a Box.

8. Appendix B

The possible positions of the parking zone

- The parking zone will be positioned using the crosses on the playground.
- The position of the parking zone is not necessary to be parallel to the wall. So, it is positioned using placing the upper-right point and the lower-right inner edge point on the crosses in order to have an angle of orientation.
- It is important to note that the nearest crosses are used to draw one of 6 virtual lines. Also, the inner edge of the parking box is aligned to one of these lines. See **figure 17** for more illustration.
- There will be a free space in front of the open side of the parking zone to ensure that it will be possible for the robot to get out of the parking zone.
- The free space is an intersection of two circles (\varnothing 920 mm) which the center of the first circle is the upper-right point and the second circle is the upper-left point of the parking zone.
- The free space should be totally free as it doesn't contain any field items.
- The free space is not colored.
- The parking zone should be positioned where the robot should not see any boxes from his starting position inside the parking zone. As described in **figure 20** and **figure 21**, the yellow area is the view rays that the robot should see from the starting position in the parking zone and it is wrong to put box in this area.

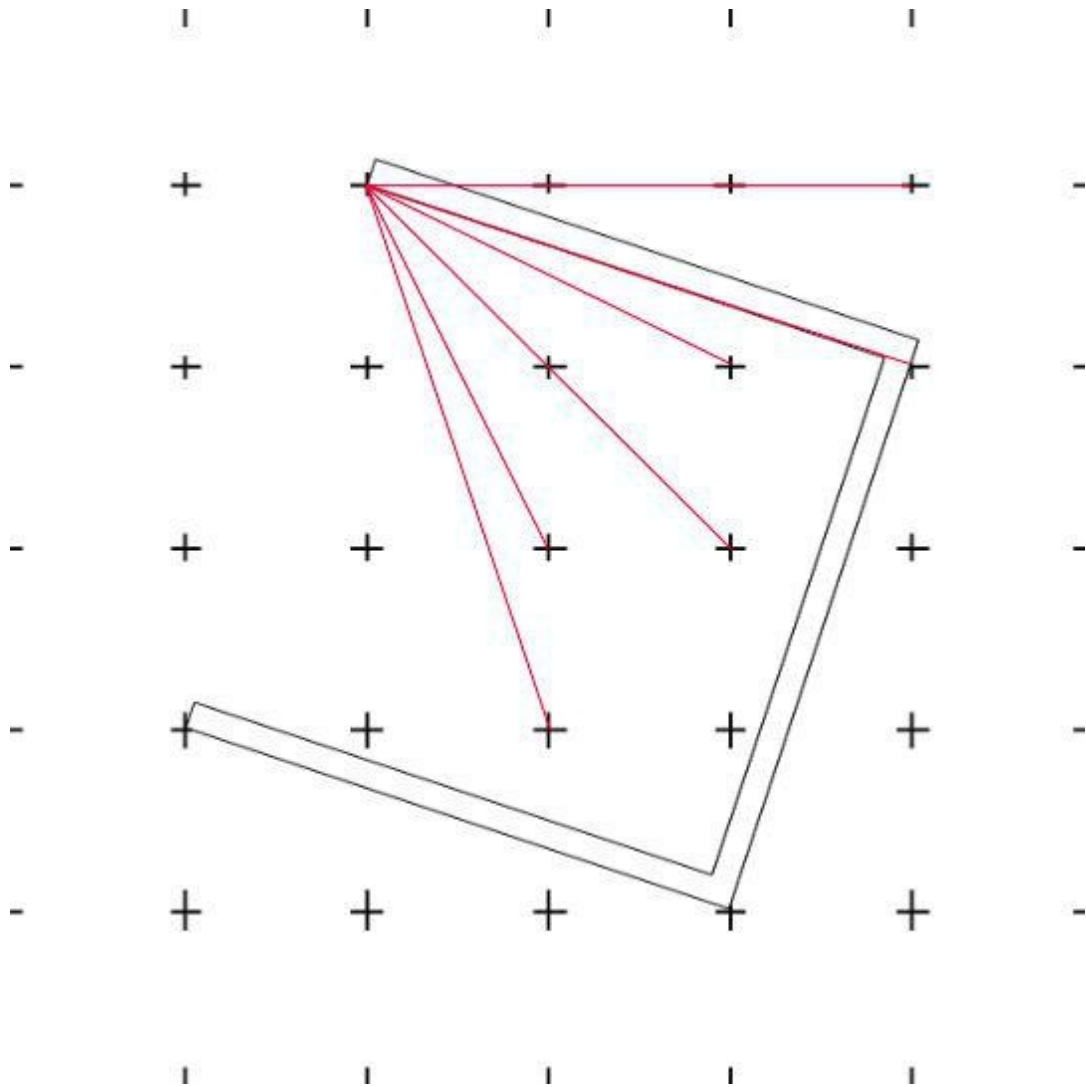

Figure 17. Illustration of position of the parking zone.

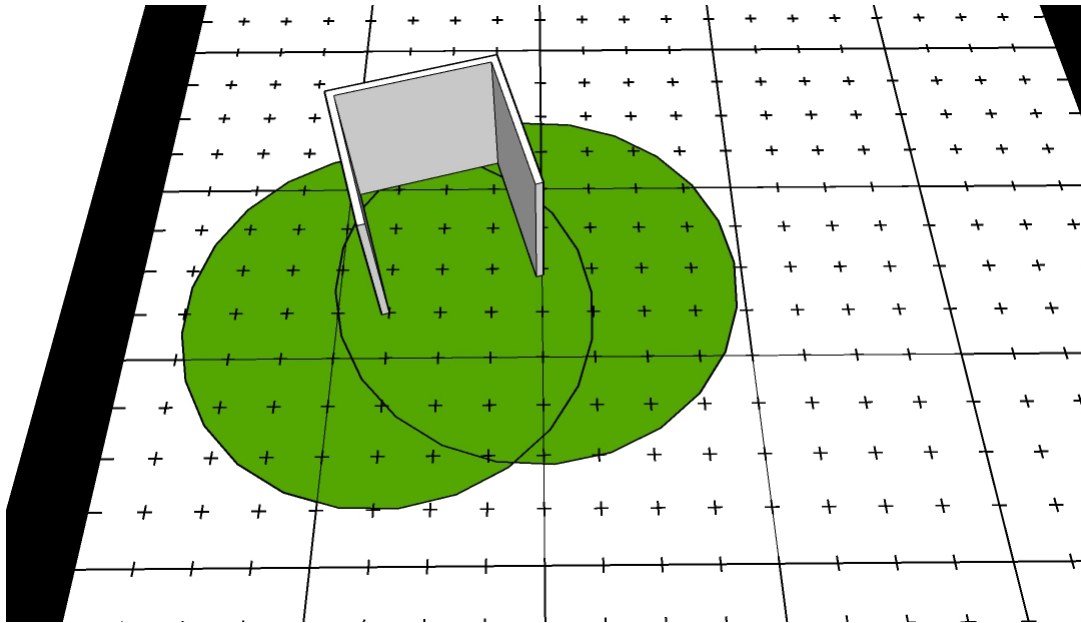

Figure 18. Right position for the parking zone.

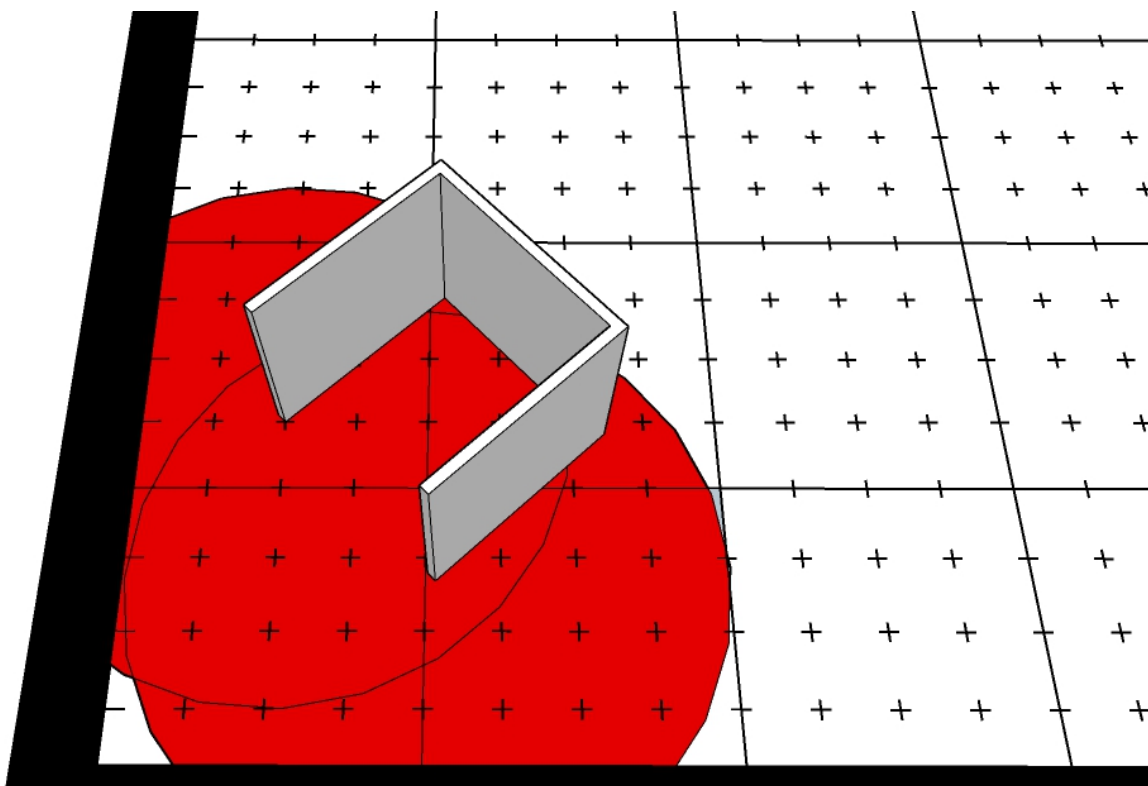

Figure 19. Wrong position for the parking zone.

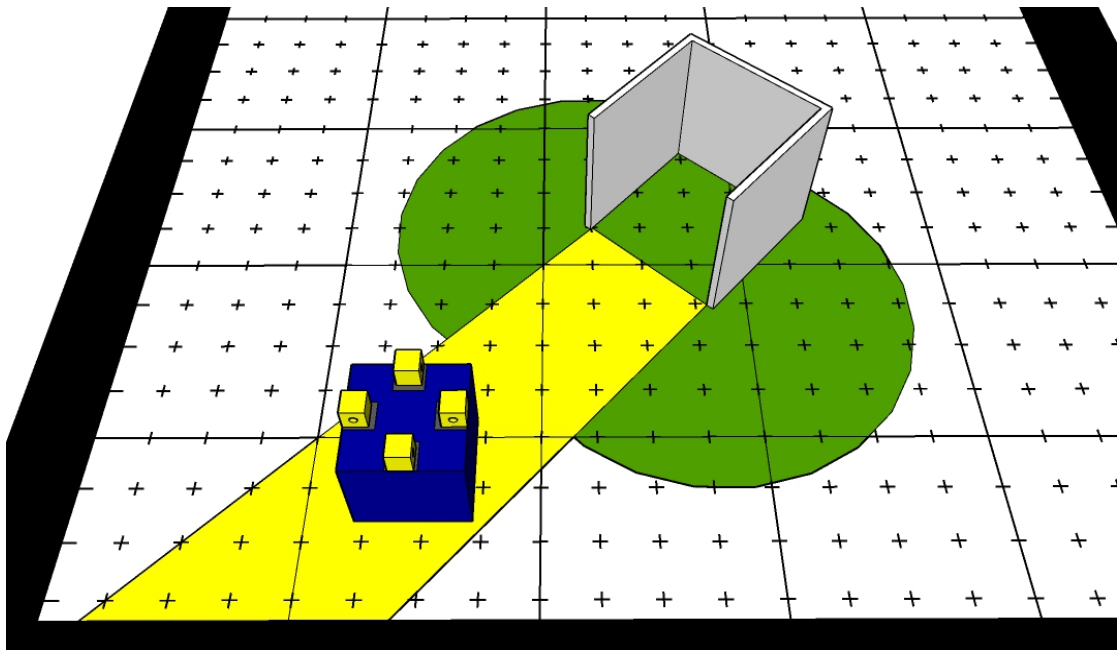

Figure 20. Wrong position for the parking zone.

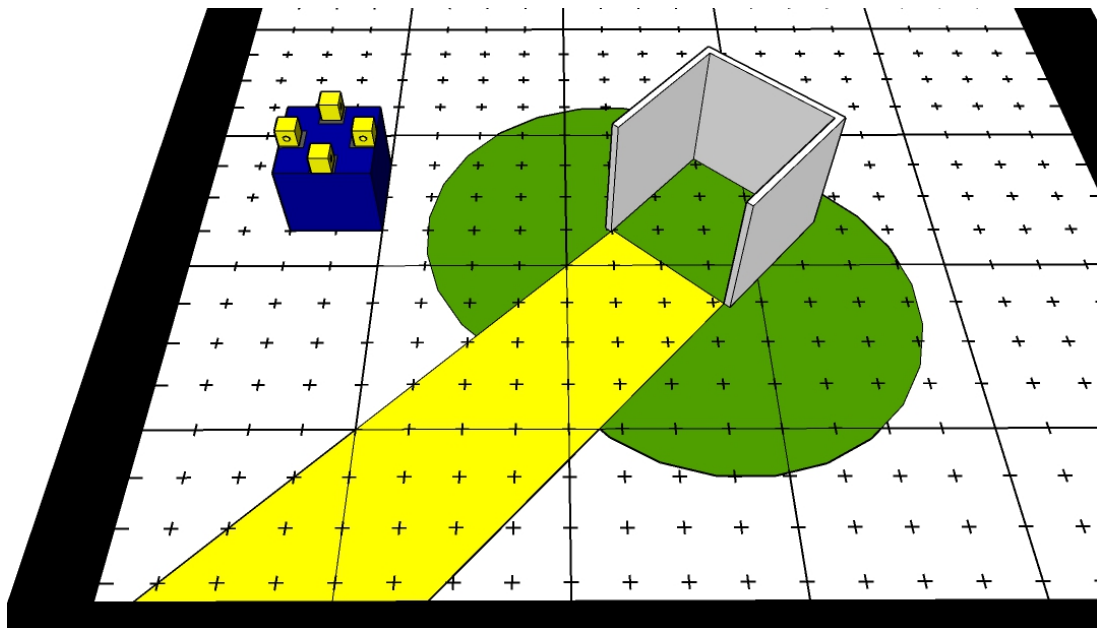

Figure 21. Right position for the parking zone.

9. Appendix C

The possible locations for game elements and the corresponding QR-codes.

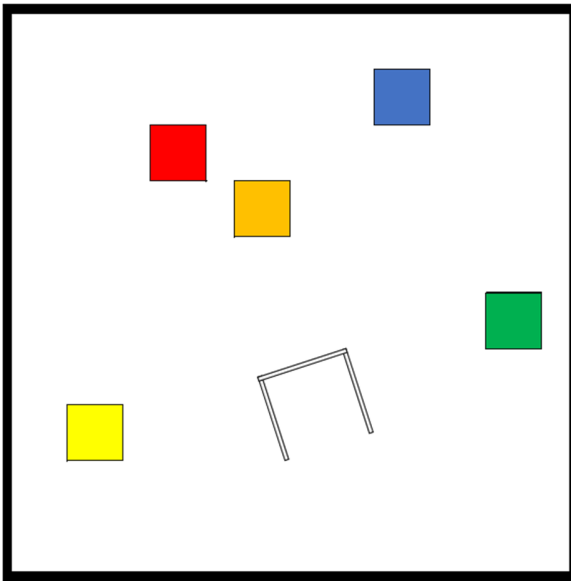

Figure 22. Locations of elements: (K,Q,J,N)(I,I,K,G)(N,C,P,E)(E,O,C,Q).

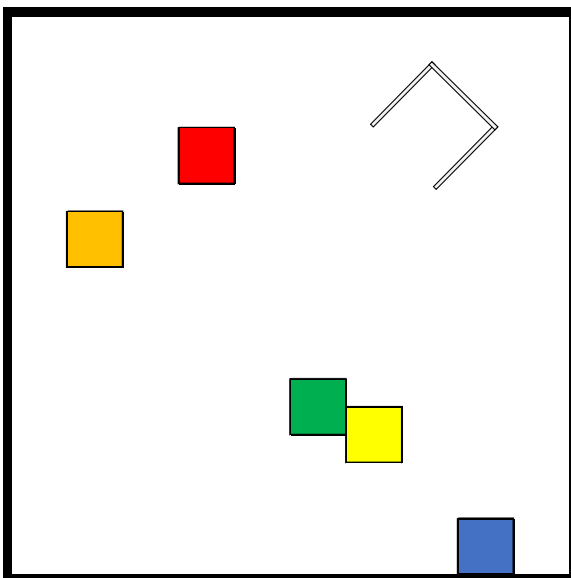

Figure 23. Locations of elements: (N,E,P,C)(M,P,K,N)(C,J,E,H)(Q,S,S,U).

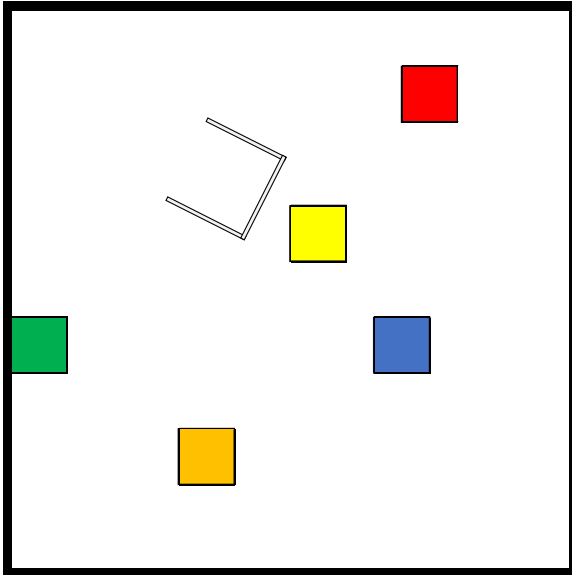

Figure 24. Locations of elements: (H,E,J,F)(N,L,P,N)(O,E,Q,C)(A,L,C,N).

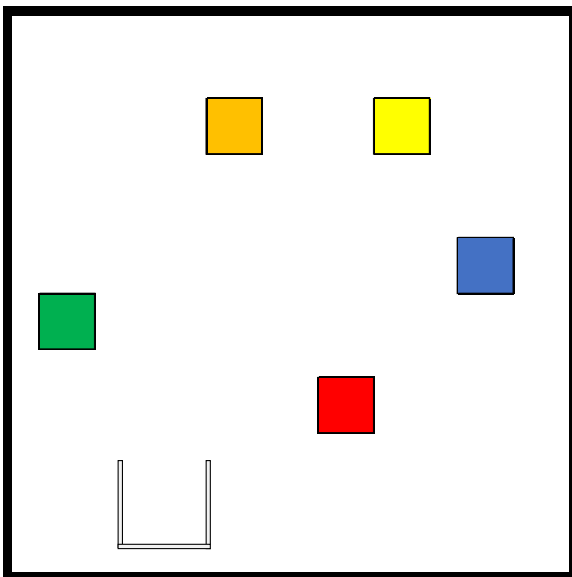

Figure 25. Locations of elements: (H,Q,H,T)(P,D,N,F)(L,N,N,P)(S,K,Q,I).

10. Appendix D

Cube's positions:

In the zone:

The cubes are positioned perfectly in the start of the round by the judges in the black guiding squares on the top of the box.

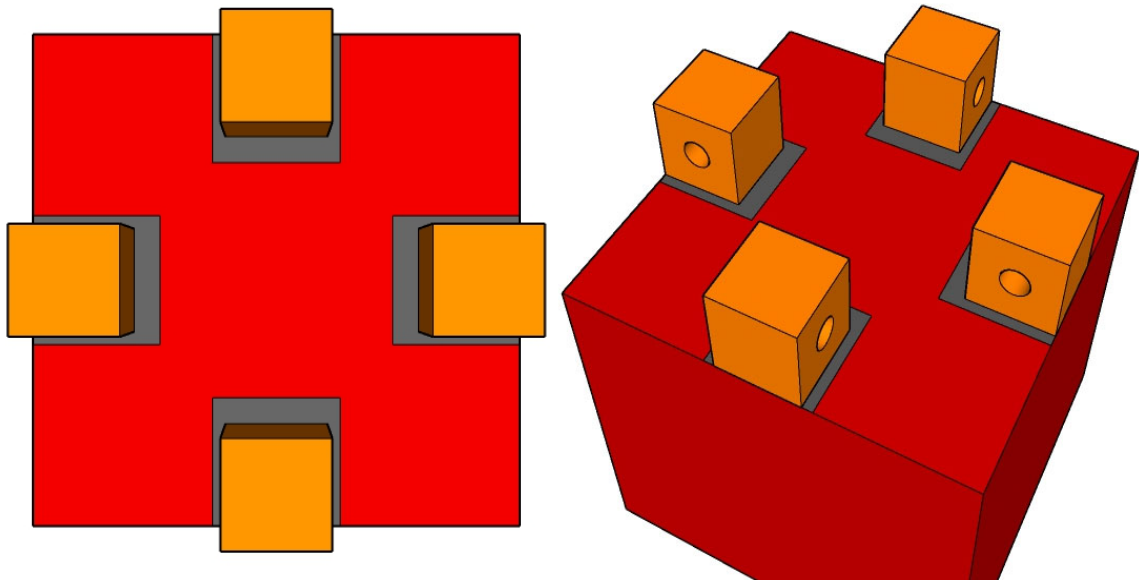

Figure 26. Cubes are perfectly positioned in the zone on top of the box.

The cube is considered positioned in the zone if the cube's projection is completely within the gray square on top of the box and no part of the cube is outside the gray square as described in the below figure.

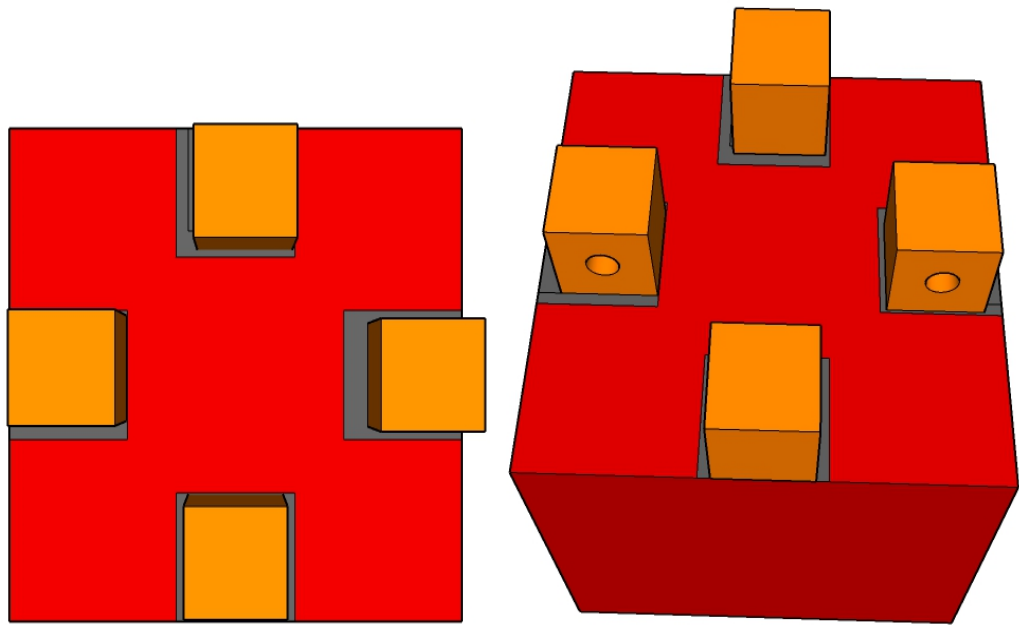

Figure 27. All cubes are positioned in the zone.

Partially in the zone:

The cube is considered positioned partially in the zone if any part of the cube's projection touches the area outside of the gray square on top of the box but there is a part of the cube's projection that is still within the gray zone as described in the below figure.

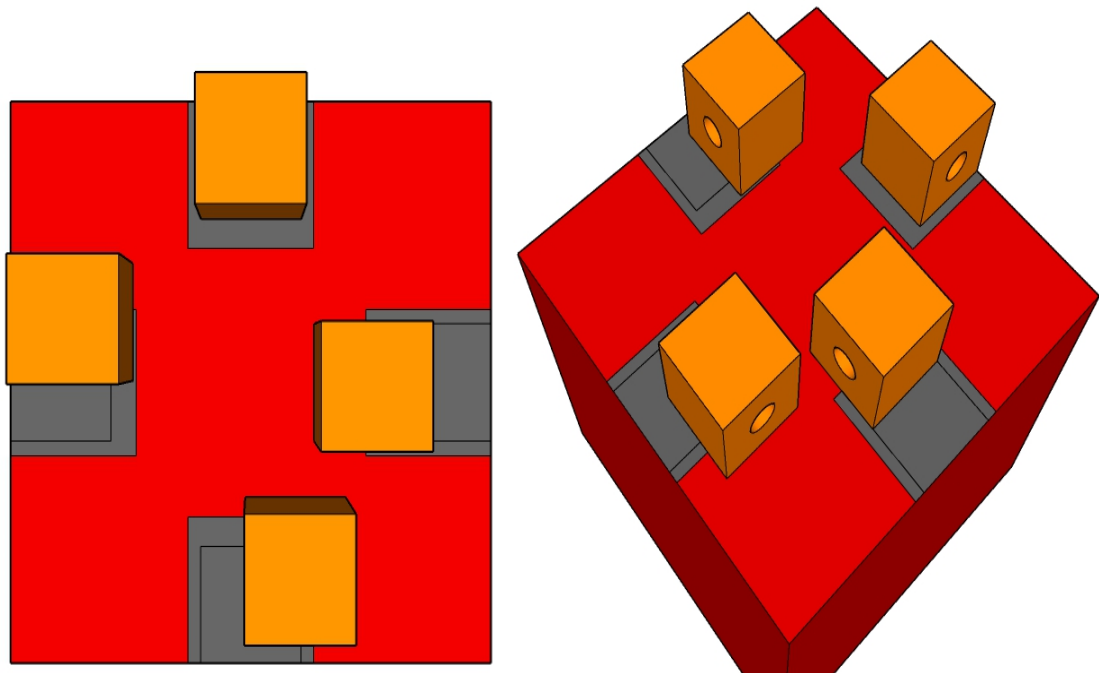

Figure 28. Three cubes (right, left and down) are positioned partially in the zone.

Out of the zone:

The cube is considered positioned out of the zone if the cube's projection is completely outside of the gray square on top of the box as described in the below figure.

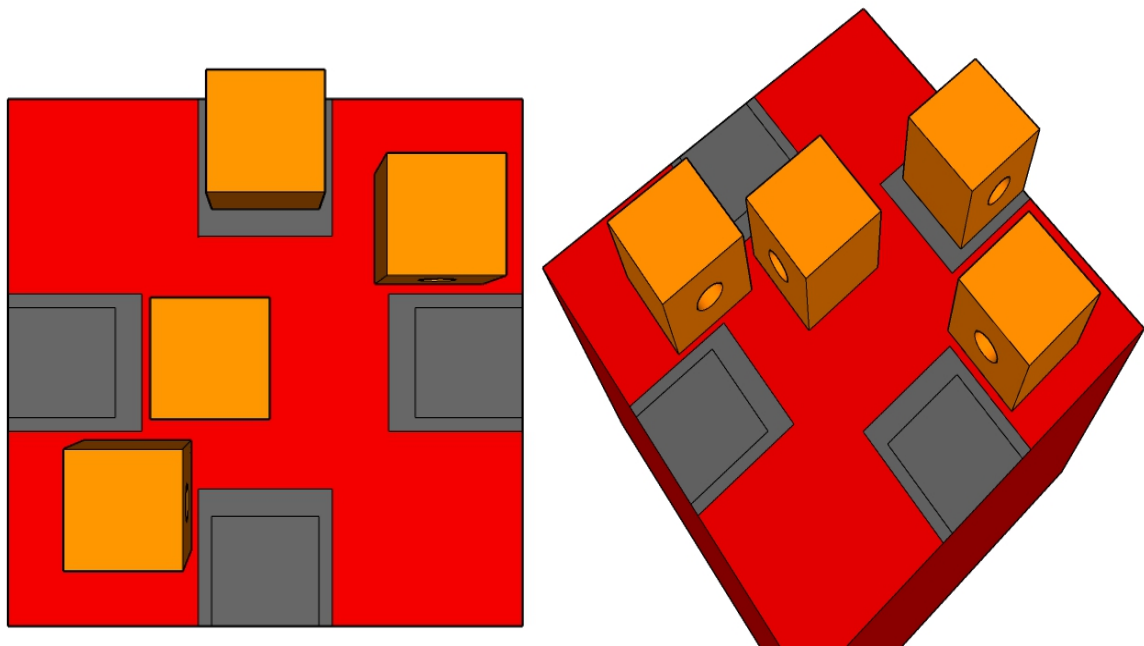

Figure 29. Three cubes (right, left and down) are positioned out of the zone.